



CABLE LENGTH	TOLERANCE*
ALL LENGTHS	+ 4% (OR 50mm) OF LENGTH - 0% (OR 0mm) OF LENGTH WHICHEVER IS GREATER
STRIP LENGTH	TOLERANCE*
0-7mm	±0.5mm
8-29mm	±1.0mm
30-49mm	±2.0mm
50-69mm	±3.0mm
70-100mm	±4.0mm
OVER 100mm	±5.0mm

\*UNLESS OTHERWISE SPECIFIED

**SOURCE DRAWING - FOR REFERENCE ONLY**

**NOTES:**

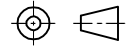
- "\*" INDICATES CABLE LENGTH IN METERS. CONTACT TURCK TO ORDER SPECIFIC LENGTHS.
- "/S90" DESIGNATES THERMOPLASTIC POLYURETHANE (TPU) CABLE.
- "/S101" DESIGNATES FLEXLIFE-20 AND CTRACK CABLE.

RELATED DOCUMENTS 1. 2. 3. 4.	3RD ANGLE PROJECTION 	THIS DRAWING IS CONFIDENTIAL AND THE PROPERTY OF TURCK INC. USE OF THIS DOCUMENT WITHOUT WRITTEN PERMISSION IS PROHIBITED.		3000 CAMPUS DRIVE MINNEAPOLIS, MN 55441 1-800-544-7769 (763) 553-7300 (763) 553-0708 fax www.turck.us
MATERIAL  SEE SPECIFICATIONS	ALL DIMENSIONS DISPLAYED ON THIS DRAWING ARE FOR REFERENCE ONLY	DRFT KMY DATE 07/02/12 APVD T.S. SCALE 1=1.0	DESCRIPTION RK 4.4T-*--PSG 4M/S90/S101	
FINISH  SEE SPECIFICATIONS	CONTACT TURCK FOR MORE INFORMATION	UNIT OF MEASUREMENT <b>MILLIMETER [ INCH ]</b>		IDENTIFICATION NO. REV D
D UPDATE SOURCE DRAWING - ADD CTRACK TO /S101 NOTE REV DESCRIPTION	CBM 02/18/14 44634 BY DATE ECO NO.	DO NOT SCALE THIS DRAWING		FILE: 777029392 SHEET 1 OF 1